



# Improve your Indoor Air Quality with UVC Air Purification

Ensure that you and your family are breathing clean air with the power of UVC technology. Simple to use and easy to install, this system mounts onto your existing forced air furnace.



**10 YEAR WARRANTY**

Effectively Purifies up to **3500 Sq. Ft.**

## PRODUCT FEATURES

- Lamps produce no ozone
- Energy efficient electronic ballast
- Safety feature designed to prevent accidental exposure to UVC light
- Built-in lamp replacement indicator (Replace lamp once a year for optimal performance)
- Safely purifies home up to 3500 sq. ft.
- Installs in less than 15 minutes



Compact and easy to install



Provides clean fresh air for the entire home



Kills germs that cause colds and flus



Alleviates allergies and asthma symptoms

**OPTIONAL INSTALLATION LOCATIONS  
ON FORCED AIR FURNACE**

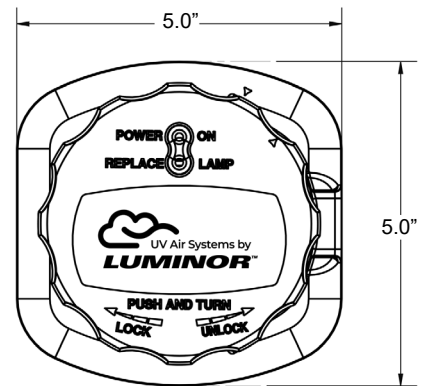
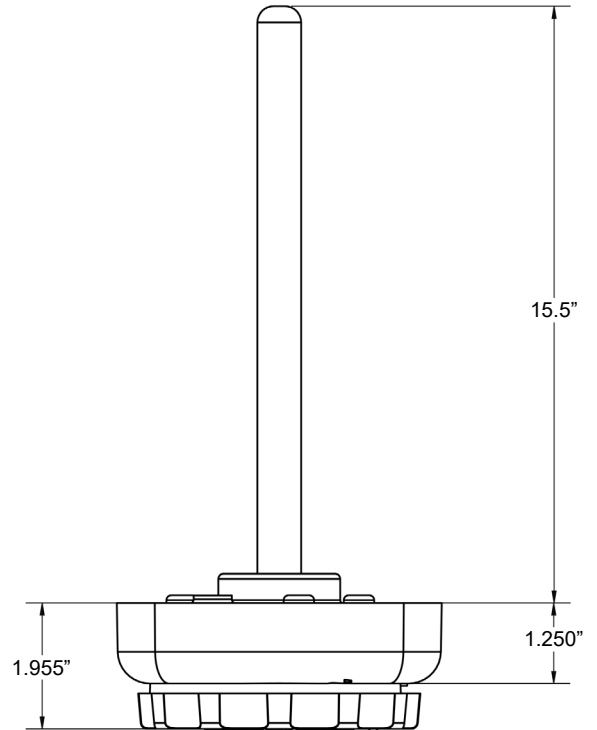
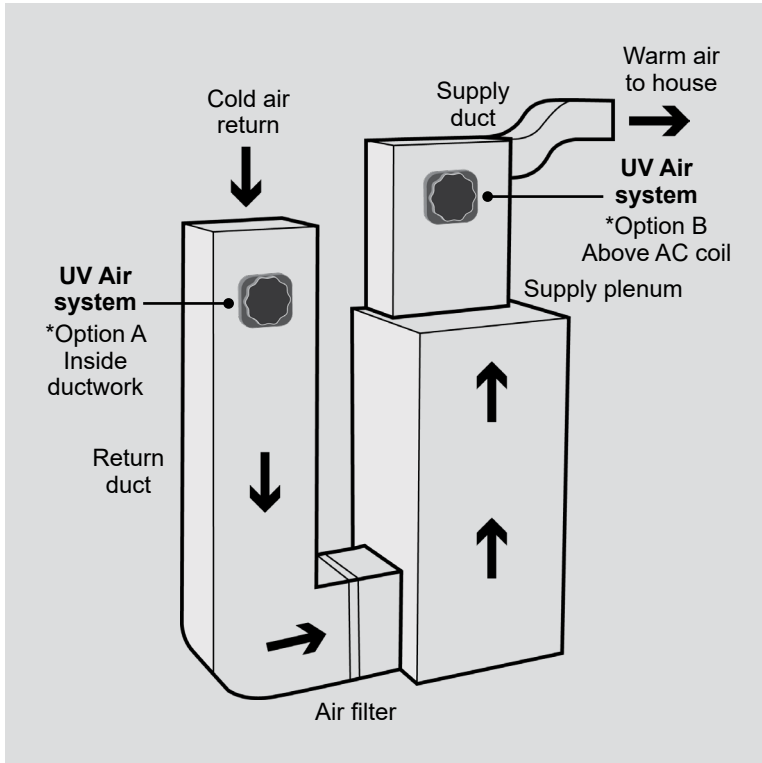

PRODUCT SPECIFICATIONS	UVAIR-01
INPUT SUPPLY VOLTAGE	108-132V
INPUT SUPPLY FREQUENCY	60 Hz
POWER (WATTS)	36
PRIMARY AMPERES	0.55A
OPERATING TEMPERATURE	-5 °C to 75 °C
OPERATING RELATIVE HUMIDITY	90%
POWERHEAD DIMENSIONS	5"(w) x 5" (h)
REPLACEMENT LAMP	UVAIR-RL1
LAMP CHANGE REMINDER	YES
LAMP OUT INDICATOR	YES
SHIPPING WEIGHT	1.0 kg (2.2 lbs)

**MANUFACTURER'S WARRANTY**

Ten (10) year Limited Warranty on the powerhead, from the date of original purchase, or installation.

See website for LUMINOR's complete warranty document including conditions and exclusions.



LUMINOR Environmental Inc.  
80 Southgate Drive, Unit 4  
Guelph, Ontario, CANADA  
N1G 4P5

P: (519) 837-3800  
TF: (855) 837-3801  
F: (519) 837-3808  
info@luminoruv.com



EPA Establishment  
#088776-CAN-001

